

EQUIPMENT MODULE OWNERS MANUAL

MODELS EM-203, EM-203T, and EM-205GT

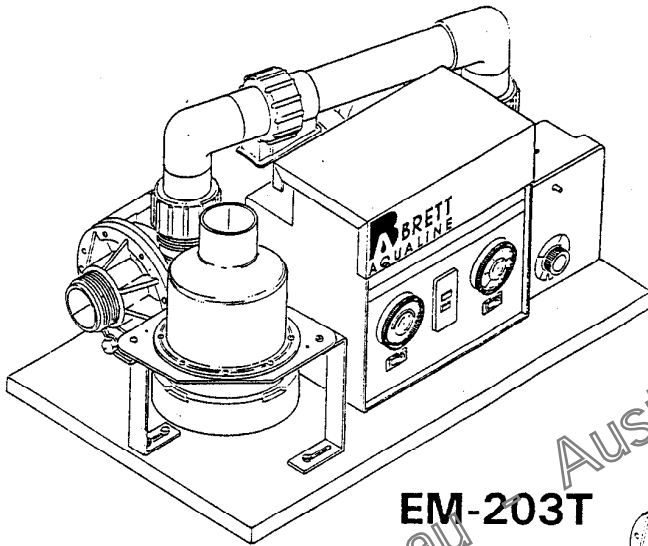

EM-203T

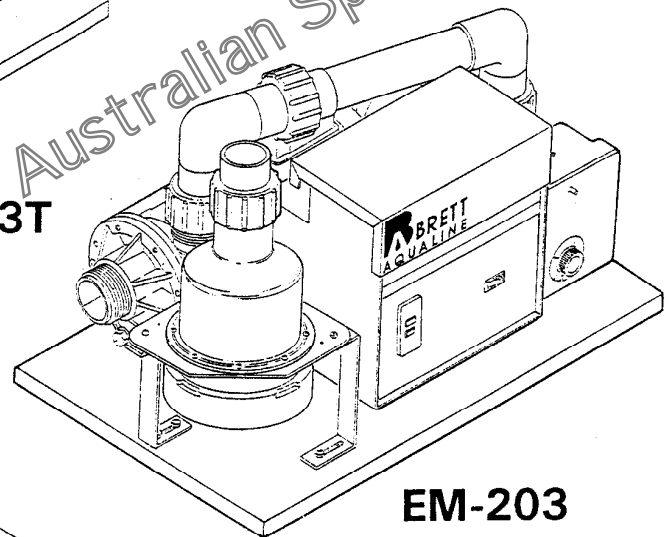

EM-203

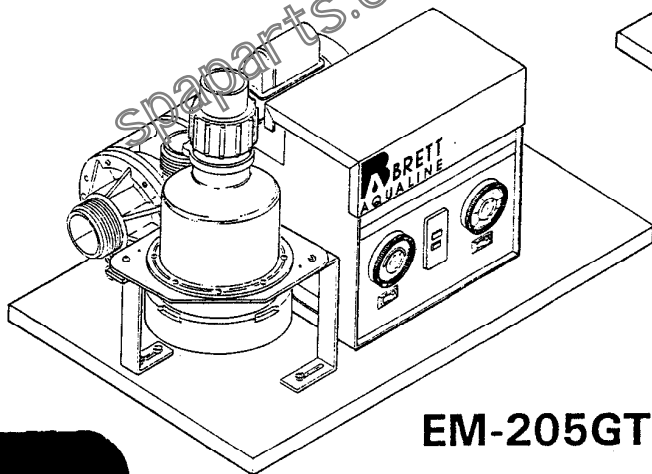

EM-205GT

B BRET
AQUALINE

5221 Oceanus Drive
Huntington Beach, CA 92649-1028
(714) 891-7211 FAX (714) 897-3284

TABLE OF CONTENTS

	<u>Page</u>
Important Safety Instructions	1
Introduction.....	4
Product Features.....	4
Installation Notes	5
Electrical - General	6
120 Volt Installation (Cord and Plug Connected Units)	6
120 Volt or 240 Volt Installation (Permanently Connected Units)	7
Initial Start-Up	8
Spa Water Temperature Setting	8
Spa Light (Optional)	9
Spa Light Lens Installation	9
Spa Light Bulb Replacement.....	9
Ozone Generator.....	9
Spa Maintenance	10
Winterizing/Vacationing Instructions	10
Trouble Shooting	11
Limited Warranty	12
The following supplementary instruction sheets may be included in this Owners Manual if the Equipment Module includes the options listed.	

<u>Options</u>	<u>Page</u>
Air Operated Spa Side Control.....	A1
Dual Timer (Units with Timers only)	A2
Pump Mode Switch (Units without Timers only)	A4
Electronic Spa Side Control.....	C1
Dual Timer (Units with Timers only)	C3
Pump Mode Switch (Units without Timers only)	C4
Gas-Fired Heater Electrical Connections (Model EM-205GT only).....	G1
Gas-Fired Heater Requiring 120 Volts (Electronic Ignition)	G1
Gas-Fired Heater With Standing Pilot Light (Millivolt Controls).....	G2

IMPORTANT SAFETY INSTRUCTIONS

When installing and using this Equipment Module, basic safety precautions should always be followed, including the following:

READ AND FOLLOW ALL INSTRUCTIONS

INSTALLATION CONSIDERATIONS

1. A bonding lug has been provided on the outside of the Equipment Module electrical control box. This lug permits the connection of a No. 8 AWG (8.4mm²) solid copper bonding conductor between the Equipment Module and all other electrical equipment and exposed metal in the vicinity, as may be needed to comply with local regulations.
2. The Equipment Module must be installed to provide for adequate drainage, and to prevent water from entering the electrical equipment area. When installing the spa and/or Equipment Module indoors, the floors and structures beneath the spa and/or Equipment Module must be protected against water run-off.

FOR CORD AND PLUG CONNECTED UNITS (120 VOLT OPERATION)

3. Do **NOT** use an extension cord. The Equipment Module must be located close enough to the electrical outlet that an extension cord shall not be required. Use of an extension cord will seriously degrade the performance of the spa, and can create a serious electrical hazard.
4. Never bury the power cord.
5. **WARNING** - To reduce the risk of electric shock, replace a frayed or damaged power cord immediately.
6. Connect **ONLY** to a grounded, grounding type receptacle rated at 120 volts, 20 Amperes. Never, for any reason, modify the attachment plug to fit other than a grounded, 120 volt, 20 Ampere receptacle.

FOR PERMANENTLY CONNECTED UNITS ("HARDWIRED" FOR 120 VOLT OR 240 VOLT OPERATION)

7. The electrical supply for the Equipment Module must include a suitably rated switch or circuit breaker to open all ungrounded supply conductors to comply with Section 422-20 of the National Electrical Code, ANSI/NFPA 70. The disconnecting means must be within sight and readily accessible to the user of the spa, but installed at least 5 feet (1.5 m) from the spa.

OPERATING PRECAUTIONS

8. **DANGER - RISK OF ELECTRIC SHOCK.** Do not permit any electrical appliance, such as a light, telephone, radio, or television, within 5 feet of the spa.
9. The Equipment Module may be equipped with a Ground Fault Circuit Interrupter (GFCI), mounted on the front of the electrical control box. This GFCI protects against electric shock hazard by sensing electric fault conditions and interrupting the electric power applied to the Equipment Module.

Before each use of the spa the GFCI, if provided, should be tested in the following manner:

1. Turn electric power to Equipment Module **ON**.
2. Push the **TEST** button.
3. The **RESET** button should pop outward, indicating that the GFCI is functioning properly.
4. Push the **RESET** button all the way in, restoring electrical power to the Equipment module.

If the **RESET** button does not pop outward when the **TEST** button is pushed, a loss of GFCI protection is indicated. Should this occur, immediately disconnect electrical power from the Equipment Module, and discontinue use of the spa until a qualified technician has identified and corrected the problem.

10. To avoid damage to the pump and heater, the Equipment Module must never be operated unless the spa is filled with water.
11. Be sure that water always flows freely from the hydrotherapy jets within the spa. Any blockage or restriction of this water flow by persons or objects may damage system components, create an electrical shock hazard, and/or cause water damage to the surrounding area.
12. **DANGER** To reduce the risk of injury to persons within the spa, never remove, or alter in any way, the grates or covers on the suction fittings in the spa.
13. **DANGER - RISK OF CHILD DROWNING.** Extreme caution must be exercised to prevent unauthorized access to the spa by children. To reduce the risk of injury, do not permit children to use the spa unless they are closely supervised at all times.
14. Before entering the spa the user should measure the water temperature with an accurate thermometer, since the tolerance of water temperature-regulating devices may vary as much as $\pm 5^{\circ}\text{F}$ (3°C).
15. The water in the spa should never exceed 104°F (40°C). Water temperatures between 100°F (38°C) and 104°F (40°C) are considered safe for a healthy adult. Lower water temperatures are recommended for extended use (exceeding 10 - 15 minutes) and for young children.

16. Prolonged immersion in water hotter than 104°F (40°C) may cause hyperthermia. The causes, symptoms, and effects of hyperthermia may be described as follows: Hyperthermia occurs when the internal temperature of the body reaches a level several degrees above the normal body temperature of 98.6°F (37°C). The symptoms of hyperthermia include dizziness, fainting, drowsiness, lethargy, and an increase in the internal temperature of the body. The effects of hyperthermia include (1) unawareness of impending hazard, (2) failure to perceive heat, (3) failure to recognize the need to exit the spa, (4) physical inability to exit the spa, (5) fetal damage in pregnant women, and (6) unconsciousness resulting in a danger of drowning. **WARNING** - The use of alcohol, drugs, or medication can greatly increase the risk of fatal hyperthermia.
17. Since excessive water temperatures have a high potential for causing fetal damage during the early months of pregnancy, pregnant or possibly pregnant women should limit spa water temperature to 100°F (38°C).
18. Never use the spa while taking medications, drugs or alcohol. Consult your personal physician regarding the effects of these substances on your body while using the spa.
19. Persons suffering from obesity or with a medical history of heart disease, low or high blood pressure, circulatory system problems, or diabetes should consult a physician before using the spa.
20. Persons using medication should consult a physician before using the spa since some medication may induce drowsiness while other medication may affect heart rate, blood pressure, and circulation.

SAVE THESE INSTRUCTIONS

INTRODUCTION

Brett Aqualine Equipment Modules are designed expressly for portable spa applications. These state-of-the-art units incorporate the finest components available, assembled in a manner intended to provide maximum enjoyment, ease of operation and years of trouble-free experience.

Please take a few minutes to read this manual; familiarize yourself with the operation of the equipment and become aware of the many superior features designed to make the ownership of your spa a thoroughly enjoyable experience.

PRODUCT FEATURES

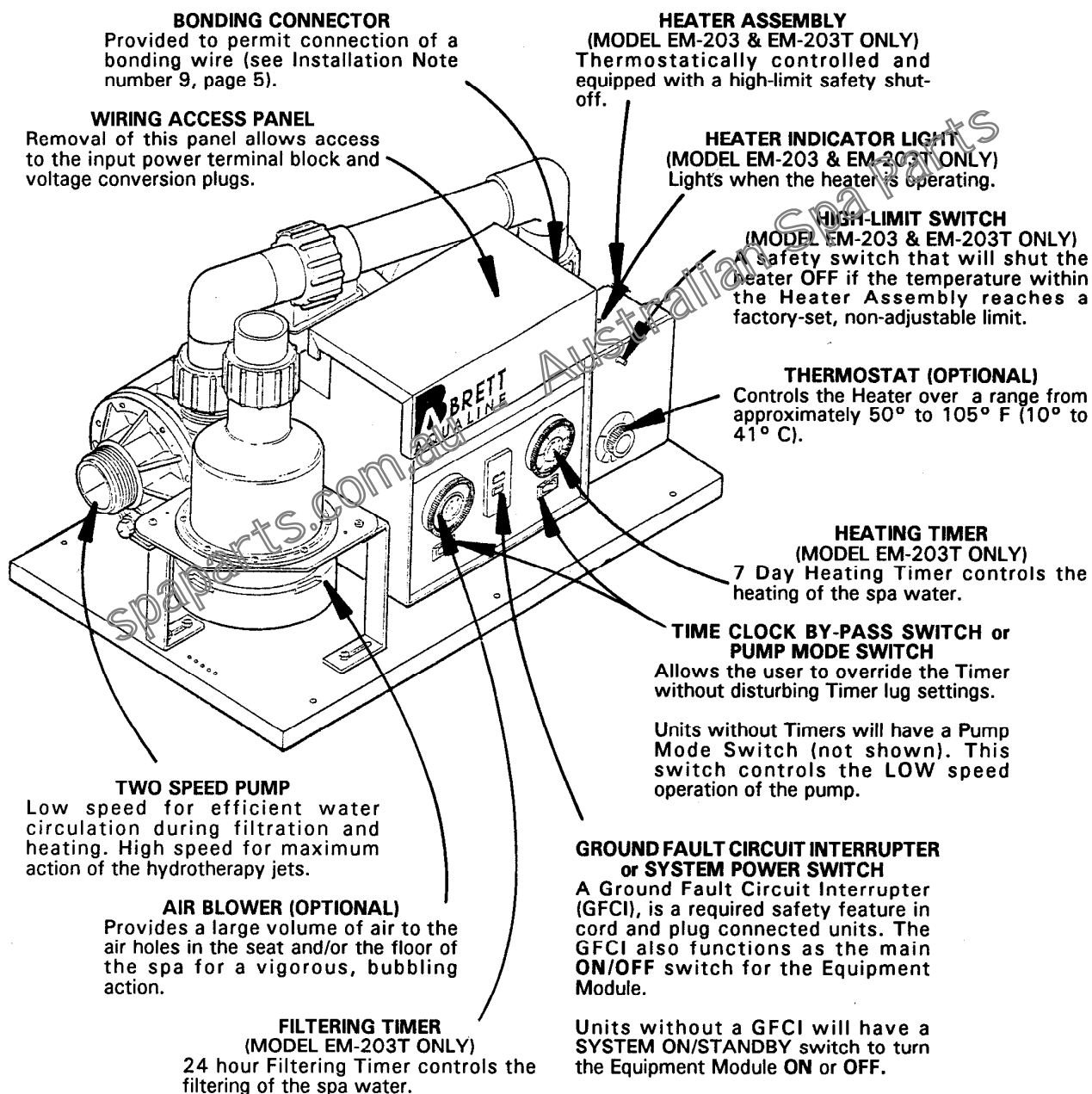

INSTALLATION NOTES

1. The Equipment Module must be protected by the skirting of a portable spa, or other weather-tight enclosure. The Equipment Module must never be installed in an open unprotected area and must **NEVER** be located above the water level in the spa. All warranties are voided if the equipment is not installed in accordance with these instructions.
2. Install the spa to provide for adequate drainage of the Equipment Module compartment to prevent water from entering the electrical equipment area.
3. Install the spa to permit safe access for servicing and routine maintenance of the filter.
4. The two-speed pump of the Equipment Module is **NOT** a self-priming type and must be installed below the water level of the spa.
5. Connections between the Equipment Module and spa are to be made with nonmetallic pipe only. The installation of shut-off valves is highly recommended.

6. The air blower on the Equipment Module, if so equipped, must be connected to a check valve and/or air-loop assembly (Figure 1) designed to assure that spa water cannot flow into the air blower motor.

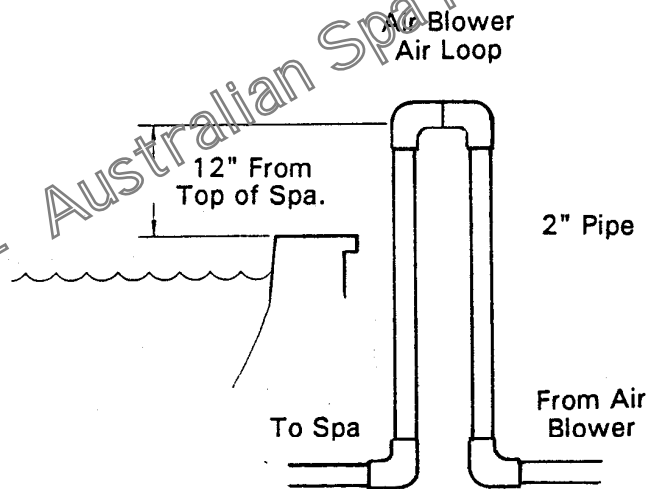

Figure 1

7. The outlet of the air blower should be connected only to the air channel of the spa. Connection of the air blower outlet to an air line associated with the spa jets may provide a path for high-pressure water to be forced back into the air blower resulting in destruction of the air blower and a potential for shock hazard. If this should occur the warranty will be voided.
8. Due to the possibility of fumes from PVC solvent cement being ignited when the air blower is first turned on, it is recommended that the connection to the air blower be made without solvent cement. If cementing is required, apply in very small amounts, and allow to dry for six hours before applying power to the air blower.
9. A bonding connector, located on the left side of the electrical control box, is provided to permit connection of a bonding wire between this point and any accessible metal surfaces within 5 feet of the spa, as needed to comply with local requirements. The bonding wire connecting this bonding connector to the accessible metal surfaces must be a solid, No. 8 AWG (8.4 mm²) copper conductor.

ELECTRICAL - GENERAL

The Equipment Module is designed to operate at either 120 or 240 volts, 60 Hz. When the Equipment Module is connected to 120 volts, the heater will provide approximately 1500 watts of heat when the pump is operating in LOW speed and the thermostat is calling for heat. When the Equipment Module is connected to 240 volts, the heater will provide approximately 6000 watts of heat when the pump is operating in LOW or HIGH speed and the thermostat is calling for heat.

Shown below, and on the following page, are instructions for connection to a 120 volt or 240 volt electrical service.

IMPORTANT NOTE: All electrical connections to the Equipment Module must be accomplished by a qualified electrician in accordance with the National Electrical Code or the Canadian Electric Code and in accordance with any local electrical codes in effect at the time of installation.

All connections must be made in accordance with the wiring information contained in this manual, in the electrical control box, or on the back of the Wiring Access Panel of the Equipment Module.

120 VOLT INSTALLATION

(CORD AND PLUG CONNECTED UNITS)

Equipment Modules provided with a factory installed power supply cord are to be plugged into a grounded, grounding type, 120 Volt, 20 ampere receptacle, shown below. **NO** other electrical appliance or fixture can be used on this circuit.

WARNING: This is a 120 volt, 20 ampere receptacle. The use of any other receptacle, or the connection of the plug to a 240 volt electrical service will cause the Equipment Module to operate improperly, create the potential for an electrical hazard, and will void the warranty.

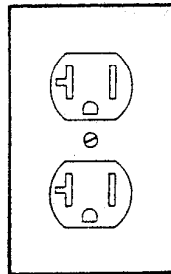

120 Volt
20 Ampere
Receptacle

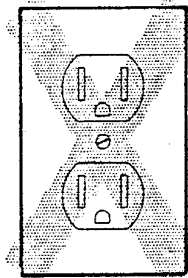

120 Volt
15 Ampere
Receptacle

NOTE: Under *NO* circumstances should an extension cord be used. Use of an extension cord will seriously degrade the performance of the Equipment Module and can create an electrical hazard.

120 VOLT OR 240 VOLT INSTALLATION

(PERMANENTLY CONNECTED UNITS)

The following instructions are for the conversion of the Equipment Module from a 120 volt cord-and-plug connected unit, to a 120 volt, *or* 240 volt, permanently connected unit.

The following procedure should be performed **ONLY** by a qualified electrician in accordance with the National Electrical Code or the Canadian Electric Code, and in accordance with any local electrical codes in effect at the time of installation.

1. Disconnect power from the Equipment Module by removing the plug from the receptacle.
2. Remove the Wiring Access Panel on the Equipment Module to allow access to the terminal block and voltage conversion plugs.
3. Remove the conductors of the power supply cord from the terminal block, then completely remove the power supply cord from the Equipment Module, and discard.
4. Connect input power wiring to the terminal block, as shown (Figure 1). All connections should be made with copper conductors. The conductors and circuit breakers or fuses must be sized to accommodate the total amperage load as specified on the Equipment Module data label.

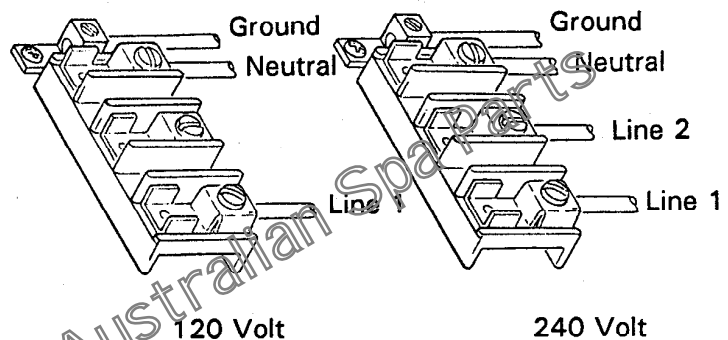

Figure 1

Equipment Modules installed for 120 volt operation require a two wire electrical service, plus ground (Line 1, Neutral, and Ground). Equipment Modules installed for 240 volt operation require a three wire electrical service, plus ground (Line 1, Line 2, Neutral, and Ground).

WARNING: Improper electrical connections or conductor sizing will cause the Equipment Module to operate improperly, create the potential for an electrical hazard, and will void the warranty.

5. For 240 volt installations **ONLY**, the voltage conversion plug, located beneath the Wiring Access Panel, must be removed from the 120 volt receptacle and plugged into the 240 volt receptacle, as shown (Figure 2). To disconnect plug, squeeze locks on side of plug and pull straight out.
6. Reinstall the Wiring Access Panel.

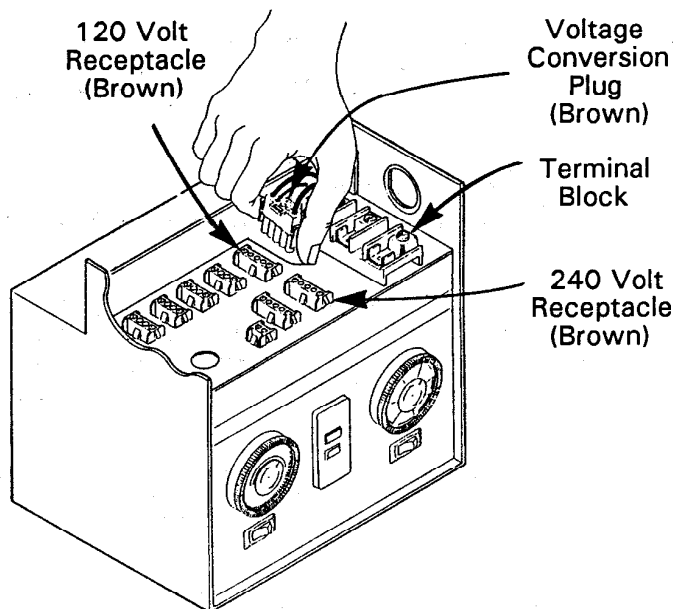

Figure 2

INITIAL START-UP

1. Turn the thermostat, located in either the heater Assembly *or* spa side control, to the **OFF** position.
2. Open all valves, if equipped, in the water inlet and/or water outlet to allow water to flow into the Equipment Module.
3. Fill the spa with water to within 6" to 8" of the top of the spa, or as otherwise directed by the manufacturer of the spa.

CAUTION: The Equipment Module must never be operated without water in the spa, serious damage to the heater and/or pump will result.

4. Check all plumbing connections for leaks.
5. With the thermostat in the **OFF** position, apply power to the Equipment Module. Press and release the red GFCI **ON** button, or turn the System power switch on, and close the equipment area door. The pump and/or the air blower will start in one of the modes described under "Air Control Operating Instructions" or "Catalina Control Operating Instructions).

IMPORTANT NOTE: It is most important that the pump be operated in HIGH speed for several minutes to assure that all air has been removed from the system before the heater is allowed to operate. Only after full water flow has been established should the thermostat be turned up.

SPA WATER TEMPERATURE SETTING

The temperature of the water in the spa is controlled by the setting of the thermostat. The thermostat may be located in the heater Assembly *or* mounted on the lip of the spa.

With the Equipment Module operating in any of the heat modes, the Thermostat will control the heater. Initially, adjust the Thermostat knob to the center of the **HOT** range. This setting will cause the water temperature to rise to 95° to 100° F (35° to 38° C). Do **NOT** expect to feel hot water coming from the jets!

The length of time it takes the water to reach desired temperature depends upon several factors: water temperature at start, ambient air temperature, spa gallonage, relative humidity, type and insulative qualities of a cover and constancy of electric power applied. An insulative cover should be kept on the spa at all times that it is not in use. Also, remember that prolonged use of the air blower and hydrotherapy jets when using the spa will have a significant cooling effect on the water.

SPA LIGHT (OPTIONAL)

All Equipment Modules have an **ORANGE** colored receptacle, located beneath the Wiring Access Panel. This receptacle is provided for the connection of an optional spa light.

If the Equipment Module is equipped with a spa light, the spa light may be turned ON or OFF by pressing the LIGHT or ACCESSORY button, usually located on the lip of the spa.

NOTE: Units with a "X" suffix in the catalog number have a spa side switch controlled, 12 volt output. All other units have 120 volts available at this receptacle at *all* times that power to the Equipment Module is ON. If a spa light operating at more than 15 volts is connected to this receptacle, a Ground Fault Circuit Interrupter (GFCI) must be provided. The conductors on the load side of the GFCI shall not occupy conduit, boxes, or enclosures containing other conductors unless the additional conductors are also protected by a GFCI.

SPA LIGHT LENS INSTALLATION

Colored lenses may be included with the spa light option. To install or remove lenses simply push ON or pull OFF of the spa light, as shown below.

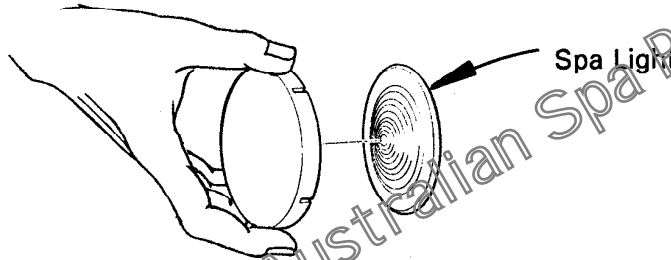

SPA LIGHT BULB REPLACEMENT

To replace the spa light bulb; turn **ALL** power to the Equipment Module **OFF**. Locate the rear of the spa light and remove the bulb socket by pulling on the socket (not the wires), as shown below. Pull the bulb from the socket and replace by reversing the above steps.

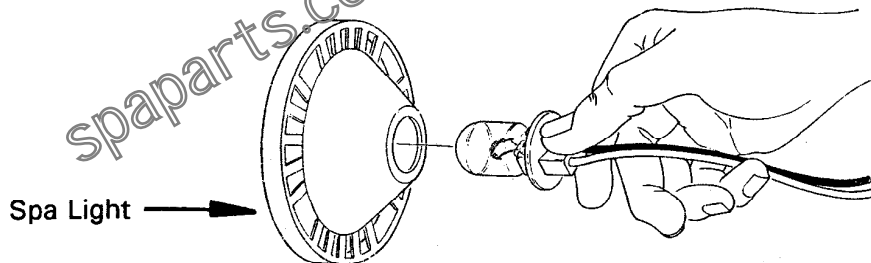

CAUTION: The replacement bulb *must* be the same rating as the factory installed bulb (Brett Aqualine replacement part number 37-0101FK2, package of two, *or* standard automotive type #912).

ELECTRICAL CONNECTION FOR OZONE GENERATOR

All Equipment Modules have a **YELLOW** colored receptacle, located beneath the Wiring Access Panel. This receptacle is provided for the connection of an ozone generator.

NOTE: 120 volts is available at this receptacle whenever the pump is operating in **LOW** speed. Therefore, an ozone generator plugged into this receptacle will operate automatically any time the pump is operating in **LOW** speed.

SPA MAINTENANCE

Contact a qualified spa or swimming pool dealer for advice on maintaining proper chemistry of the spa water. Please be aware that the mineral content of spa water increases from water evaporation and with the addition of algaecidal and sanitizing chemicals. If the mineral concentration of the water becomes too high, the minerals will precipitate and deposit on the spa, in the filter, and on the heater.

Algaecidal and sanitizing chemicals are either alkaline or acidic. Sodium and calcium hypochlorite are alkaline. Chlorine gas and practically all other dry chlorine products are acidic. Whichever type of chlorine is used, it is *extremely* important that the pH level be checked frequently and maintained between 7.2 and 7.8.

CAUTION: Do *NOT* store spa or pool chemicals near the Equipment Module because their corrosive fumes may cause damage.

The spa water must be changed when the amount of dissolved solids becomes excessive.

NOTE: Change the spa water frequently, typically every 3 to 4 months or when the water clarity and cleanliness can no longer be maintained by chemical treatment.

It is recommended that the total alkalinity of the spa water be kept from 80 to 100 parts per million (ppm) when sodium or calcium hypochlorites are used, and 100 to 120 ppm when other dry chlorine products or chlorine gases are used.

CAUTION: Failure to maintain the proper chemical levels as stated above may cause excessive damage to components in contact with the spa water. Damage to components determined to be the result of improper chemical maintenance will *NOT* be covered under the warranty.

Clean the filter regularly. A dirty filter restricts pump and heater performance.

If for any reason it becomes necessary to repair the Equipment Module or spa, contact a qualified spa dealer for servicing.

WINTERIZING/VACATIONING INSTRUCTIONS

If the spa is to be left unused for an extended period of time, it may be desirable to turn the heater OFF. This is accomplished by rotating the thermostat control COUNTERCLOCKWISE (CLOCKWISE on units with electronic spa side control) to the OFF position. To keep the spa water clean and sparkling, set the Pump Mode switch to the CONTINUOUS OPERATION position or set the Filtering Timer (model EM-203T only) to filter the water several times each day as needed. When preparing the spa for use, check the water chemistry to assure correct chlorine and pH levels.

If the spa is located in an area where freezing temperatures can occur, and it is not desirable to drain the spa for the winter, set the thermostat to the LOW or FREEZE position, and set the Heating Timer or Pump Mode switch to the THERMOSTAT CONTROL position. The pump and the heater will operate as required to prevent the water from freezing.

If the spa is to be drained for an extended period of time, and located where freezing temperatures exist, make sure *all* water has been drained from the spa. When *all* the water has been drained from the spa, use a 9/16 inch wrench to remove the pump drain plug, located on the lower front of the pump housing, and drain *all* water from the pump housing. Replace the pump drain plug. Close all water shut off valves, if equipped. Check the spa manufacturers instructions regarding winterizing the filter assembly and spa plumbing. Covering the spa is highly recommended.

TROUBLE SHOOTING

A. UNIT WILL NOT OPERATE:

1. Try resetting the Ground Fault Circuit Interrupter (GFCI), if equipped. To reset the GFCI press and release the RESET button. If the GFCI trips repeatedly, immediately discontinue use of the spa and contact a qualified technician to correct the problem.
2. Check the main circuit breaker panel. If the circuit breaker has tripped, reset breaker. If the circuit breaker trips repeatedly, contact a qualified electrician to correct the problem.
3. For cord and plug connected units only, check the receptacle used for the Equipment Module by plugging in another electrical appliance. If appliance does not work, contact a qualified electrician to correct the problem.

B. PUMP WILL RUN BUT THERE IS NO WATER FLOW:

1. Make sure that all valves, if equipped, are in the open position.
2. Clean the filter if necessary.
3. Make sure that the spa suction lines are free of debris.

C. PUMP RUNS AND THERE IS WATER FLOW BUT NO HEAT:

1. Turn the thermostat **CLOCKWISE** (COUNTERCLOCKWISE on units with a Catalina Controls, electronic spa side control) to a higher temperature setting. Do **NOT** expect to feel hot water coming from the jets.
2. Try resetting the heater high-limit switch, located in the heater assembly. Reset by pressing the red button inward. If the high-limit trips repeatedly, contact a qualified electrician to correct the problem.
3. Make sure that the operating mode the Equipment Module is presently in, is a mode that will allow the heater to come ON. Refer to Operating Instructions.
4. Make sure that all valves, if equipped, are open, to allow a full flow of water through the system. Limited water flow will NOT build up enough pressure to allow the heater to come on.
5. Clean the filter to assure maximum water flow.

D. WATER WILL NOT ATTAIN PROPER TEMPERATURES:

1. The spa should have a thermal cover. A spa will lose the majority of its heat from the surface of the water.
2. Turn the thermostat **CLOCKWISE** (COUNTERCLOCKWISE on units with a Catalina Controls, electronic spa side control) to a higher temperature setting.

E. PULSATING OR MINIMAL WATER FLOW IN HIGH SPEED MODE:

1. Check the water level of the spa. It should be above the highest jet or skimmer.
2. Make sure all valves, if equipped, are open.
3. Make sure that the filter is full of water.
4. Make sure that the filter is clean.
5. Check the spa suction lines, remove debris if necessary.

F. WATER DOES NOT CLEAR UP:

1. Make sure that the filter is clean.
2. Check the water chemistry for proper chemical balance.
3. If the Equipment Module is equipped with a Filtering Timer, increase the Filtering Timer setting.

G. BLOWER WILL NOT BLOW AIR INTO THE SPA:

1. Check the air blower connections for leaks.

H. UNIT WILL RUN BUT WON'T SWITCH MODES OF OPERATION:

1. Make sure that the air tube, or electrical cord, from the spa side control is attached properly to the Equipment Module.
2. Units with an air operated spa side control, make sure air tube is NOT pinched.

I. PUMP TURNS OFF AFTER LIMITED USE:

1. The Equipment Module may be equipped with an internal 30-minute pump timer. To restart the pump, press the spa side FUNCTION/JETS button.

LIMITED WARRANTY

Brett Aqualine, Inc. warrants its Equipment Modules produced after September 1, 1987 to be free from defects in material and workmanship for a period of three (3) years from the date of purchase, except as noted below. Products which become defective within the warranty period will be repaired or replaced (at **Brett Aqualine's** option) except for damage related to water chemistry, negligence, abuse, misuse, misapplication, unauthorized modifications, improper installation, or normal wear and tear. This warranty extends only to normal, personal (noncommercial) usage by the original retail purchaser within the continental United States including Alaska and Hawaii. Pump seals, pump motors, o-rings and gaskets, air blower brushes, and remote spa-side controls with associated electronic printed circuit board assemblies are covered by **Brett Aqualine's** warranty only during the first year of the warranty period. Some remote spa-side controls with associated electronic printed circuit board assemblies furnished by **Brett Aqualine** are made by other manufactures who might have longer warranty periods.

Brett Aqualine will be responsible for labor incurred only by its authorized service agents in removing, inspecting, and reinstalling the warranty products only during the first year of the warranty period; however, **Brett Aqualine** will not cover any labor costs attributable to disassembly and reassembly of the spa, skirt, decking or other materials enclosing the **Equipment Module**, or attributable to difficulties in gaining access to the **Equipment Module**. **Brett Aqualine** will not be responsible for labor costs of anyone not an authorized service agent or for routine maintenance, adjustments or alterations to the calibration of electrical devices.

Any products which are claimed to be defective and which are not repaired or replaced by an authorized service agent must be shipped freight prepaid to **Brett Aqualine** and the repaired or replaced product will be returned to the sender freight collect. When sent to **Brett Aqualine**, the product must be accompanied by the sales receipt or other proof of purchase date, as well as the sender's name, mailing address, daytime telephone number and any other information relating to the sender's claim.

Unless state law expressly provides otherwise, **Brett Aqualine** will only be responsible for repair or replacement of any of its products that are found to be defective as provided above, and will not bear the cost of any incidental or consequential damages. This warranty gives you specific legal rights and you may also have other rights which vary from state to state.